

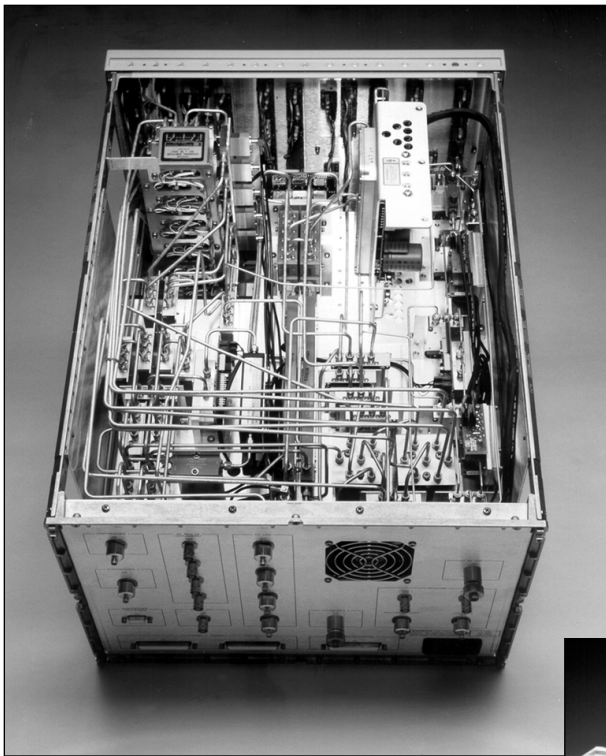

Agilent Custom Switch Matrices

Product Note



Agilent Technologies
Innovating the HP Way

Table of Contents

3	Introduction
3	The function of the switch matrix
4	Electrical specifications
9	Switch drivers
10	Switch matrix designs
12	Mechanical specifications
14	Ordering process
15	Deliverables
15	Conclusion
16	Appendix A
16	Switch matrix specification form
18	Appendix B
18	Popular Agilent coaxial switches
21	Appendix C
21	Agilent switch drivers and interface modules

Introduction

Over a period of more than ten years, Agilent Technologies has developed a standard design and manufacturing process for making high-performance custom switch matrices. Agilent designs matrices that are optimized for your application and specifications. This product note describes what a switch matrix does, and explains the advantages of using a switch matrix in an RF/microwave test system. It also helps you determine the critical parameters and other design requirements for a matrix that will meet the needs of your application. Electrical and mechanical specifications that have significant impact on matrix performance are analyzed, and different microwave switching designs are described. For each design, we cover characteristics that could make one design more suitable than another for your application. Finally, special features and functions that add value and ease of use to your switch matrix are discussed.

The function of the switch matrix

Virtually all automatic microwave test systems use a computer-controlled coaxial switch matrix to route signals between test instruments and the device under test (DUT). The matrix allows multiple measurements to be made automatically, with a minimum number of manual connections to the DUT. A matrix can also provide signal conditioning by incorporating amplifiers, filters, attenuators, and frequency translating devices such as mixers and multipliers. Since all stimulus and response signals must pass through the switch matrix, the characteristics of the matrix signal paths directly affect the accuracy and integrity of all measurements. It is impossible to design a switch matrix that does not degrade the original signal. However, the matrix can be optimized to meet the key performance requirements of the application. Agilent uses high-performance coaxial switches in all of its switch matrices, unless otherwise specified by the customer. Agilent switches meet high standards of performance, with exceptional reliability (>5 million cycles), repeatability (less than 0.03 dB), VSWR (typically 1.2:1), and isolation (typically >90 dB). In this product note, electrical specifications assume the use of Agilent switches in the matrices. Appendix B includes specifications for some of the most popular Agilent switches. For complete information, refer to the *RF and Microwave Test Accessories Catalog*, publication number 5964-9527E.

Electrical specifications

The electrical parameters described below are key specifications that should be considered when ordering a custom switch matrix. By providing these specifications you will help Agilent design engineers make the best design choices for your application. Critical specifications should be highlighted to ensure that our design complies with them. We use our experience and the latest technology to meet or exceed your requirements. If a parameter is not specified, we optimize the design for the best overall performance. The more completely you define your requirements, the better we can optimize your matrix for not only performance, but for price and features, as well.

VSWR

VSWR in a switch matrix is directly related to the VSWR of the coaxial switches used in the matrix. The VSWR of the switches is determined by the mechanical dimensions and tolerances used in their manufacture. Agilent switches are manufactured with a mechanical tolerance of ± 0.0005 inch.

Agilent switch matrices are designed to avoid the worst-case VSWR of the switches by selecting switches optimized for the specific frequency range of your application. VSWR is also minimized by choosing cable lengths to prevent reflections from adding at specific frequencies, and by the use of low-ripple power dividers where appropriate. If VSWR is a critical factor in your application, we can further minimize it by using isolators or attenuators at the input and output ports and at critical points in the RF path.

Insertion loss

Low insertion loss is important because power is expensive, especially at high frequencies. The importance of insertion loss in your application depends on the power requirements of your DUT, the input and output power requirements of the stimulus and response instruments in the system, and noise considerations. Insertion loss is related to the switches and other components used in the matrix, the cables that route the signals and other aspects of the design. To minimize insertion loss in

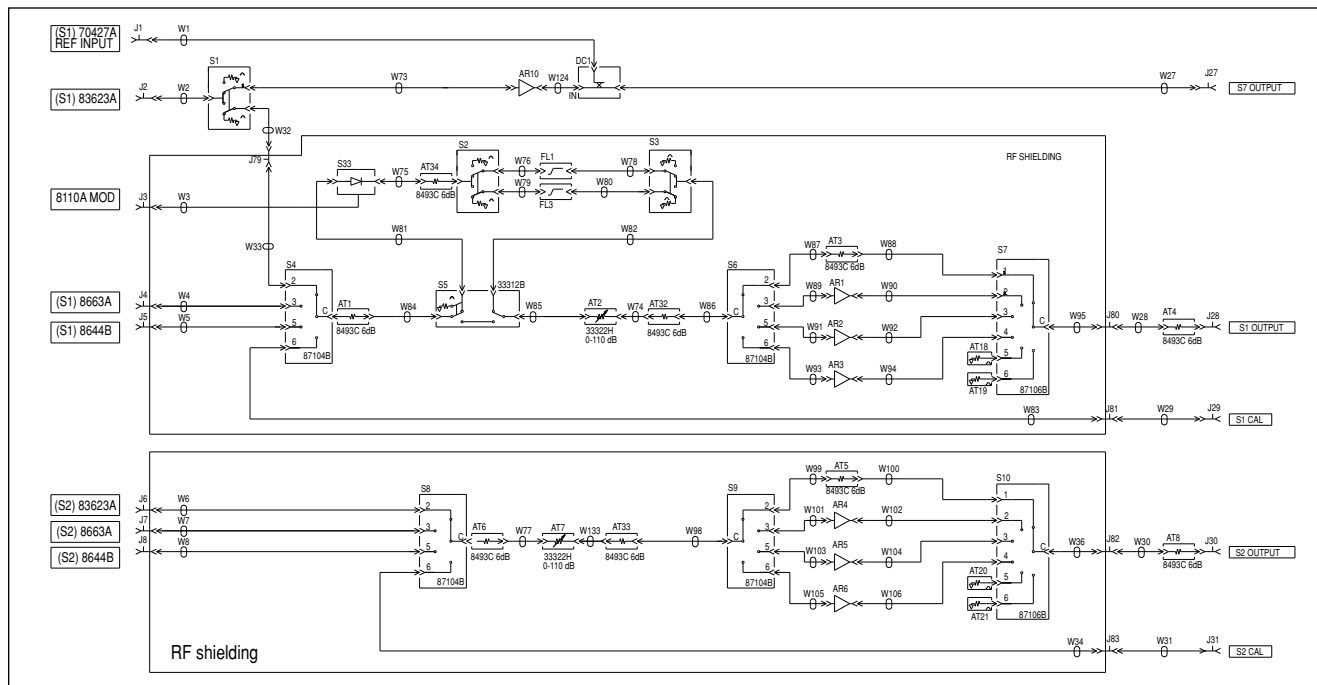

Figure 1. In the above high isolation design, RF shielding compartments separate RF paths providing 115 dB in signal isolation.

a critical path, the cable length of the sensitive path can be minimized by careful placement of components near to each other and to input/output connectors; also, by selection of couplers, isolators, and other components for the band of interest (rather than for unspecified wideband operation).

A specification that is important in many applications is insertion loss ripple. This is a small up and down variation (typically specified over a narrow band) in the insertion loss, caused by VSWR reflections from components such as dividers and couplers. Ripple can be minimized by using isolators and/or pads in key paths. Ripple values of 0.2 dB over a 100 MHz bandwidth at 18 GHz are typical of Agilent matrices.

Isolation

A switch matrix with high isolation helps assure measurement integrity, especially if high- and low-power signals are routed through the matrix simultaneously. Isolation is the amount by which an unwanted signal is attenuated before it is detected at the port of interest. For example, a matrix may have to route a signal to a spectrum analyzer for measurement at -70 dBm and to simultaneously route another signal at $+20$ dBm. Switches with 90 dB or more isolation keep the measurement integrity of the low-power signal in this example. Our experience has led to the selection of the types and manufacturers of connectors, adapters, and other components that yield the highest isolation. In addition, for increased isolation, signal paths may be separated by using multiple switches and careful routing. If your application is highly sensitive to signal cross talk in specific paths, we may place isolation shields around the sensitive path and use special components that are constructed with low RF leakage.

Reliability

The reliability of a switch matrix depends on the life of each of its switches and on the total number of switches used. Agilent switches are guaranteed to meet specifications over 5 million cycles (typically 10 million). The following is a comparison of replacement frequencies for Agilent switches and switches with a lower specified lifetime in an example application.

Switch reliability comparison

This example is a high-volume component or module test application in which switches experience 5,000 closures per 8-hour day (10 closures/min.).

Using Agilent switches:

replacement frequency = 5 million / 5,000 =
1,000 days = ~2.7 years

Using switches with a lifetime of 1 million cycles:

replacement frequency = 1,000,000 / 5,000 =
200 days = 6 months

Note that many switch manufacturers do not specify the number of cycles over which the switch is guaranteed to meet specifications, but the number of cycles to destruction. Agilent guarantees that its switches will meet all specifications for a minimum of 5 million cycles.

Repeatability

Repeatability is a measure of the changes in insertion loss or phase for a switch matrix path from cycle to cycle over time. Repeatability ensures accurate test results. S-parameter repeatability is critical because it cannot be calibrated out with test software. Insertion loss repeatability of Agilent switches is better than 0.03 dB, and insertion loss repeatability of most switch paths through Agilent switch matrices is typically about 0.06 dB, due to random averaging of cascaded repeatability. Phase repeatability is typically 0.2 degrees per switch at 20 GHz.

Termination

A 50-ohm load termination is critical in many applications, since each unused segment of coax transmission line—if unterminated at one end—may resonate at a frequency where it is one-half wavelength long and at all higher-frequency harmonics. These resonances can “suck out” signal power at high Q at specific frequencies. This can be quite important when designing a matrix up to 26 GHz or higher, where switch isolation drops considerably. Terminating unselected transmission line segments prevents this problem.

Signal leakage into unterminated switches reduces isolation performance as well. In some Agilent switches, such as the 8762, 87104, and 87106 multiport switches, all ports are matched. That is, any unselected port is switched to an internal 50-ohm load.

Termination is important if reflected power from a signal source on a matrix input line would damage or affect the operation of the source. Also, if the input is one of a pair of lines from a power splitter, the other line’s insertion loss ripple would be increased by reflections on the first unterminated line (see Figure 8). Thus, when switches are at outputs of the power dividers, unused ports of the switches should be terminated. However, termination is usually not needed when switching between response instruments, since if an instrument is not selected to be read, it does not matter if the signal routed to the instrument is noisy. If high VSWR is acceptable on some unselected paths, we can offer a lower-cost matrix by choosing unterminated switches and more flexible designs.

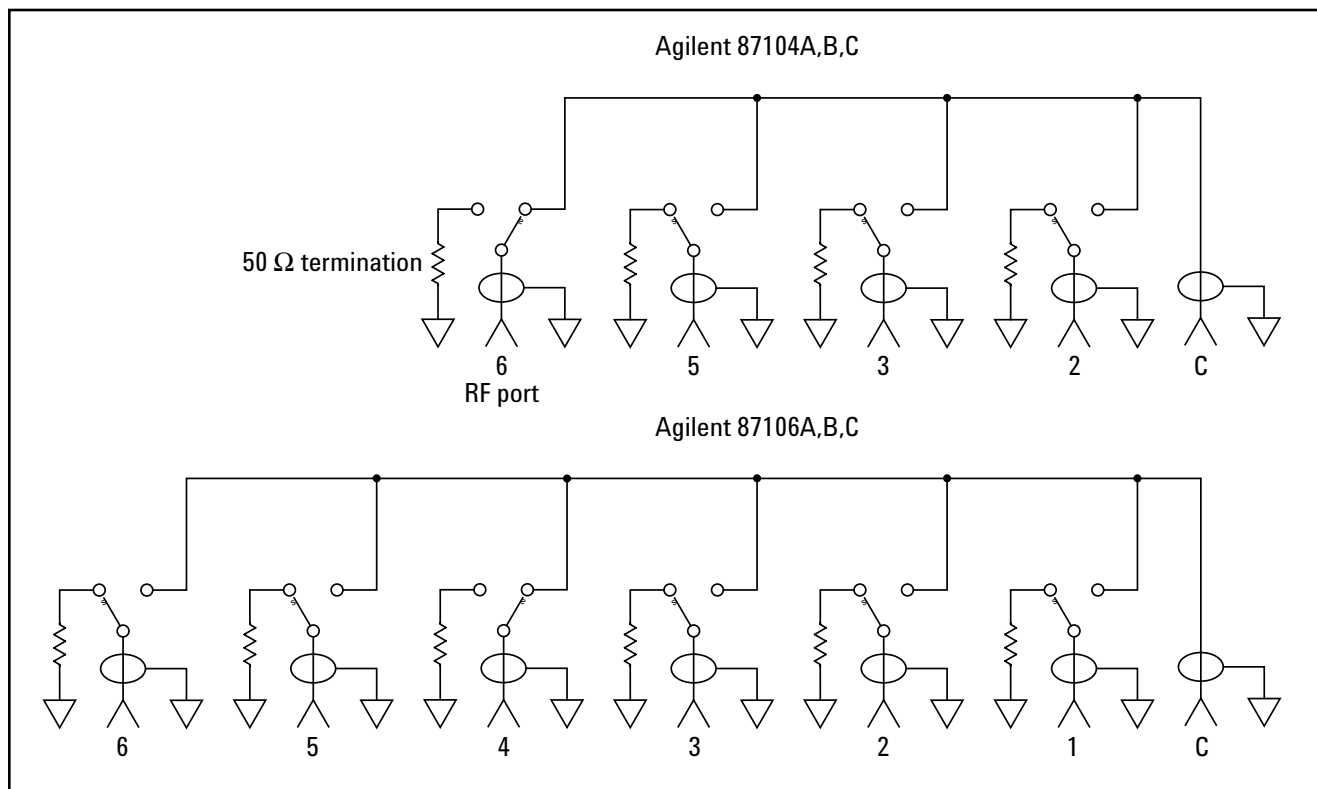

Figure 2. Simplified block diagram of Agilent 87104A/B/C and 87106A/B/C multiport switches

Frequency of operation

Agilent designs RF and microwave switch matrices that operate from DC to 50 GHz. By using special connectors and switches, we can design for higher frequencies. Based on your specified frequency range of operation, we choose a design that is optimized for your requirements. The higher the frequency, the more critical the routing and cabling of the signals becomes to measurement integrity. Specifying a low-frequency limit is as important as specifying a high-frequency limit, because wideband components are expensive and can have more insertion loss. Therefore, we recommend that you specify the narrowest band possible for your application.

Power specifications

One advantage of using a switch matrix in your ATE system is that signal conditioning can be incorporated within the matrix. Based on your power requirements, we may use attenuators and/or amplifiers to provide the optimized power to your DUT. Power sensors can also be coupled to the critical path for very accurate power measurements.

Equal path/equal phase

Some applications require equal length on several paths through the matrix. Since each equal path presents the same test condition to the DUT, in many applications you can test or calibrate one path and apply the results to all the other DUTs connected to other equal paths. By using CAD and automatic bending equipment to manufacture semi-rigid cables, Agilent can provide equal paths within 0.015 inch for many applications. Some applications require equal paths for amplitude match and some for phase match. To meet very tight phase-match specifications, we sometimes use phase adjusters. In many cases, however, using Agilent semi-rigid cables designed for your application and performing extra testing to assure equal specifications provides phase match without expensive phase adjusters. For example, without using phase adjusters, we can guarantee signals in different paths at 18 GHz to be within 10 degrees.

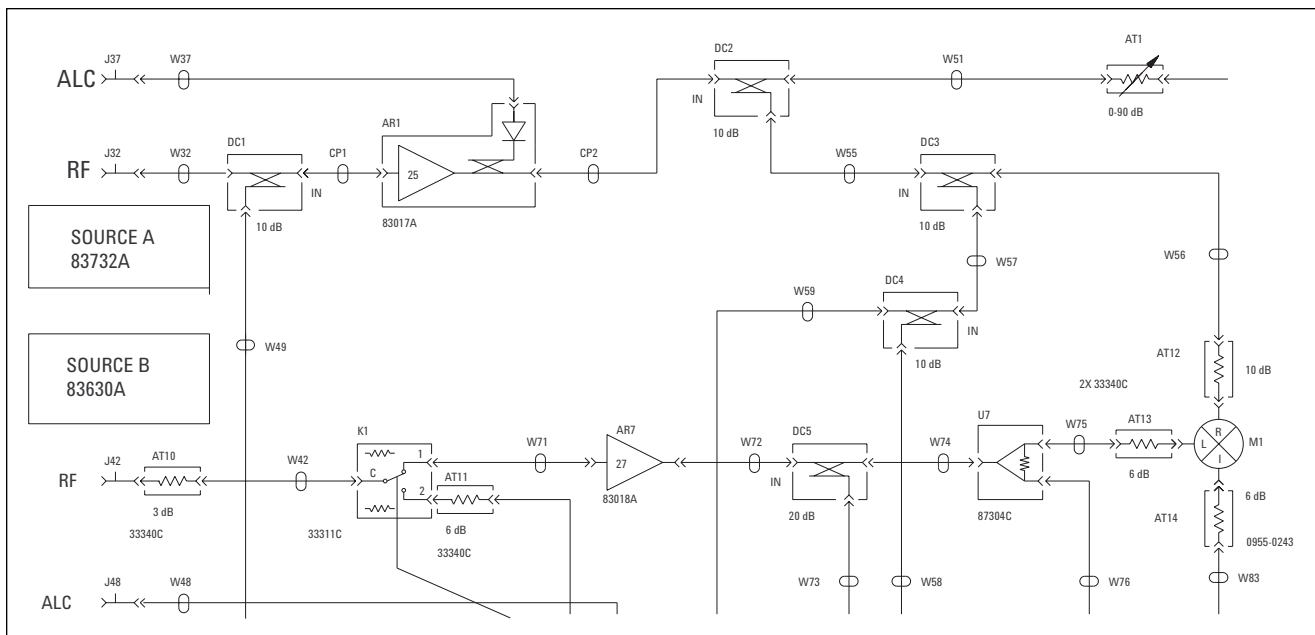

Figure 3. This switch matrix has incorporated an ALC directional detector, a 27 dB gain amplifier, several directional couplers, a programmable attenuator, fixed attenuators, power splitter, and mixer.

Switching speed

Agilent microwave coaxial switches are break-before-make switches. Switch speed is between 15 and 30 milliseconds. We can design register-based drivers for faster switching speed. For applications that require even higher switching speed, we build matrices using fast, solid-state PIN switches, with a switching speed in the nanosecond range.

Signal conditioning and matrix characterization

As mentioned above, one advantage of having a switch matrix in a system is that signal conditioning can be obtained within the matrix. We use amplifiers and attenuators to satisfy power requirements. Filters and isolators can be used for selecting or

deleting a signal through a specific path. We also use phase- and frequency-translating devices such as mixers, doublers, and dividers to provide the right frequency for operating the DUT or for up/down conversion. Detectors and noise sources may also be installed. These devices are permanently connected with semi-rigid coaxial cables; no external cabling is needed. The result is a compact, convenient, one-box solution.

Some applications require frequent calibration of the ATE system and the switch matrix. If your application requires this, we incorporate calibration and characterization paths, and install power sensors in these critical paths.

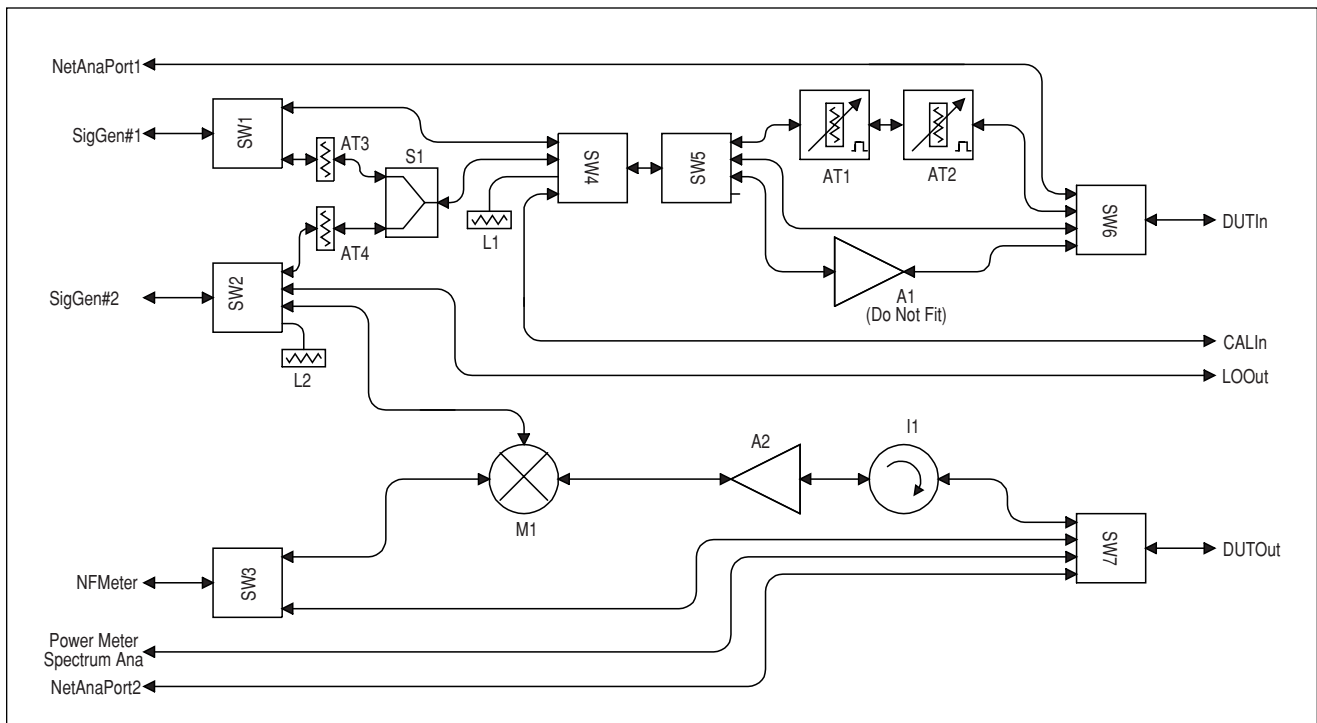

Figure 4. This component testing switch matrix has a calibration path through the matrix for ease of calibration.

Switch drivers

Your custom switch matrix can be controlled remotely through GPIB, using switch drive instruments or devices. If your application requires another mode of control, such as RS-232, RS-422, register-based, or even custom remote control, we can provide a quote for you. If your switch matrix is controlled through GPIB, then the 87130A switch driver, 11713A attenuator/switch driver, 3488A switch control unit, or 70611A switch/attenuator driver for MMS modules can be used to control the switches.

The Agilent 87130A is a rack-mounted driver, designed to be incorporated into the system II mainframe to provide a complete switch matrix solution. The 87130A does not include manual control capability. The Agilent 11713A can control as many as 10 switches and provide both the solenoid DC driver power and GPIB for automated programmability. It also has manual control and LED indicators. The Agilent 3488A provides GPIB control for up to 80 switches, but requires an external power supply. The Agilent 70611A is a 1/8 module switch/attenuator driver, designed to be incorporated into an Agilent modular measurement system (MMS) mainframe. It has graphical/manual control capability to provide a total, integrated ATE solution.

The Agilent E1442A is a register-based VXI general purpose switch driver that can control up to 64 switches or channels. Refer to Appendix C for more information on Agilent switch drivers.

The solenoid control lines from each switch in the matrix are typically routed to back panel connectors for convenient connection to an Agilent 11713A, 3488A, 70611A, or 87130A. Agilent can also integrate driver circuitry within the switch matrix, with all the necessary power supplies. However, if you choose standalone switch drivers, our designers need to know which switch driver you will be using, since each driver uses a different control logic.

Switch matrix designs

When specifying a switch matrix for your system, first determine how many inputs and outputs the matrix needs. This is called an $n \times m$ matrix, where n is the number of inputs and m is the number of outputs. The next step is to determine if each input needs to be connected to one output or to several outputs and if different paths are activated simultaneously or in sequence. This important information helps our design engineers choose a combination of the following three basic switch matrix designs.



Figure 5. Agilent 11713A (upper left), 70611A (upper right), and 87130A (bottom).

Common highway

Features:

- Can connect any input to any output

Advantages:

- Simplest design
- High isolation
- Lowest cost
- Wide bandwidth

Disadvantages:

- Can connect to only one output at a time
- Higher insertion loss with large configuration

Example specifications at 12 GHz matrix in Figure 6.

- Insertion loss = 1.3 dB (typical)
- VSWR at input port = 1.3:1 (typical)
- Isolation = 90 dB
- Repeatability = 0.05 dB

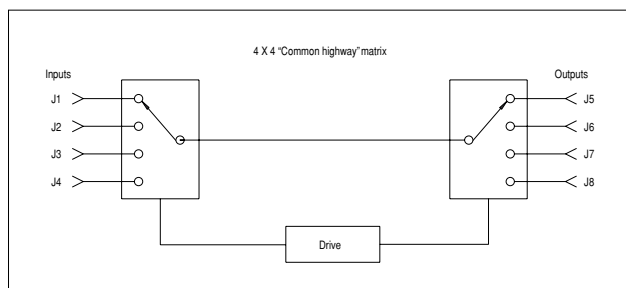

Figure 6. 4 x 4 "common highway" matrix

Full access (blocking)

Features:

- Can connect any input to any output
- Multiple active channels simultaneously

Advantages:

- High flexibility
- High isolation
- High throughput
- Bi-directional
- Low insertion loss
- Wide bandwidth

Disadvantages:

- Any input can connect to only one output at a time
- Higher cost

Example specifications at 12 GHz for matrix in Figure 7.

- Insertion loss = 1.3 dB (typical)
- VSWR at input port = 1.3:1
- Isolation = 90 dB
- Repeatability = 0.05 dB

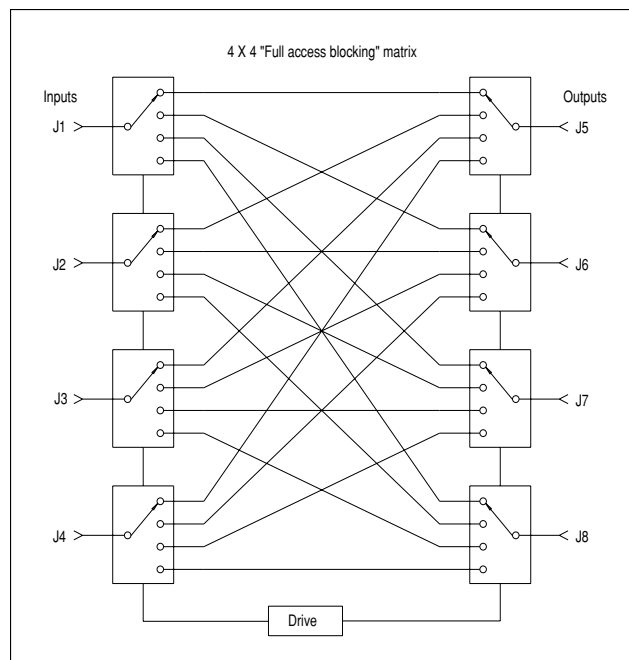

Figure 7. 4 x 4 "Full access blocking" matrix

Full access (non-blocking)

Features:

- Can connect any input to any output simultaneously
- Multiple, simultaneous active channels
- Can connect any input to all outputs simultaneously

Advantages:

- High flexibility
- High throughput
- High isolation between outputs not connected to the same input

Disadvantages:

- Low isolation between outputs connected to the same input
- Bandwidth limited by power divider
- Higher insertion loss

Example specifications at 12 GHz for matrix in Figure 8.

Insertion loss = 8 dB (typical)

VSWR at input port = 1.6:1 (typical)

Isolation = 20 dB (outputs connected to some input)

Isolation = 90 dB (outputs connected to different input)

Repeatability = 0.05 dB

Application specific matrices

As mentioned above, the final design is usually a combination of the three basic matrices and other application-specific design elements to satisfy your electrical requirements. However, in some cases, the final design is very application specific and does not resemble any of the basic matrices. Figure 4 is an example of a matrix designed for component testing.

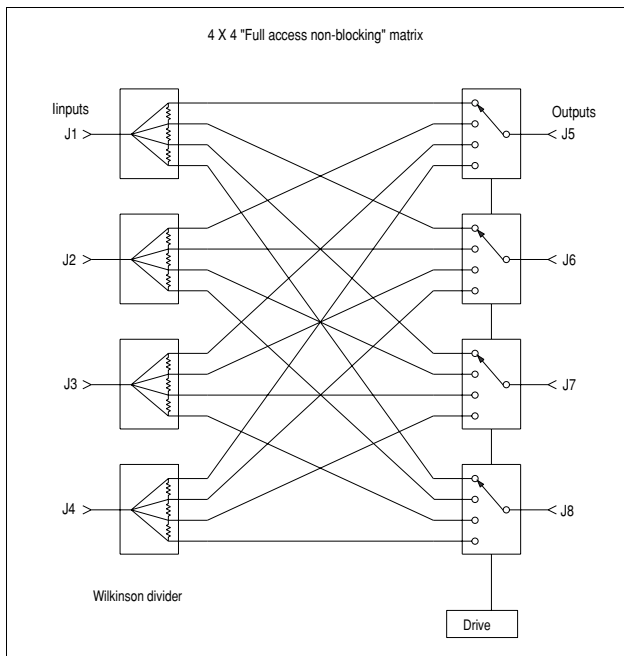

Figure 8. 4 x 4 "Full access non-blocking" matrix

Expanding a switch matrix

If your ATE system requires provisions for future expansion, we use a building block design (Figures 9 and 10) that leaves unused terminals for later expansion of the matrix. Compared to similar designs without the provision for expansion, this design uses approximately 10 to 15 percent more switches and cables. The result is a more flexible design, but the cost is usually 10 to 15 percent higher. Also, performance cannot be as highly optimized.

Mechanical specifications

Switch matrix platforms

Agilent custom switch matrices are available in three different platforms:

1. Rack-and-Stack (Agilent system II):

The Agilent 8760 series matrices are rack-mount boxes with connector type and location designed to your specification. If your application imposes size and/or weight constraints on the matrix, please specify these. The frequency of operation is DC to 50 GHz.

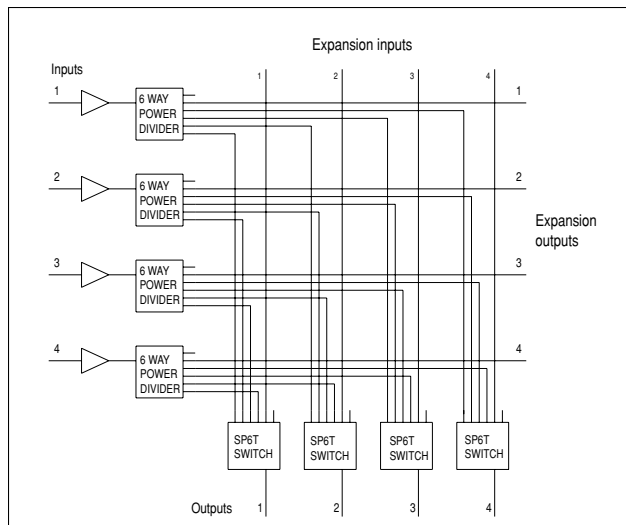

Figure 9. 4 x 4 "Non-blocking full access building block" matrix

2. VXI:

The Agilent E6490 series are custom switch matrices in the VXI platform. The frequency of operation is DC to 26.5 GHz.

3. MMS:

Agilent provides custom switch matrices up to 50 GHz in the MMS platform. These are the Agilent 70612X series matrices. In addition to these custom solutions, Agilent offers a family of standard MMS switch matrix modules. These are the 70612A/C and 70613A/C. For more information on these matrices, refer to the MMS catalog, publication number 5965-2818.

Connectors

When ordering a matrix, specify the RF connectors. In addition to frequency range, the expected number of connections and disconnections determines the best connector. Connector savers are recommended, since system repeatability depends on good connections and the cost of replacing original connectors is high.

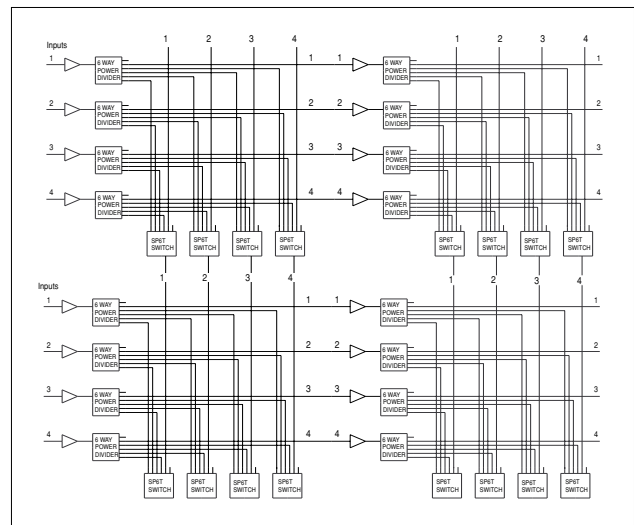

Figure 10. 8 x 8 "Non-blocking full access building block" matrix

For applications to 18 GHz, request SMA connectors if there is to be little connector wear. A low-cost connector saver is available from Agilent (part number 1250-1462, SMA male-to-SMA female adapter). For greater durability, order Type-N or APC-7 connectors.

For operation up to 26.5 GHz, there are three alternatives:

1. APC-3.5 female connectors with replaceable inner and outer conductors;
2. APC-3.5 male connectors with female-to-female adapters; and
3. APC-3.5 male connectors with a precision adapter.

Above 26.5 GHz, APC-2.4 connectors are usually required.

Agilent can also build matrices with Blind Mate connectors and any other type of connector you request.

Readback, front panel schematic, and LEDs

Matrices can be designed in two ways: with or without a provision called readback for determining the position of each switch and attenuator. Readback can be obtained in three ways:

1. Immediate position verification of the last switching command by an Agilent 87130A or 70611A driver. This “sense” mode only occurs after switching (speed is about 50 ms) and cannot be used as an “interrogator” at times other than immediately after switching. Software commands for switching with this readback system are slightly more complicated than without readback.

2. The Agilent 3488A with 44474A digital I/O cards installed can provide position verification at any time using the “read” or “view” command. The 3488A also has manual push-button capability. When the number of switches is high, the 3488A becomes a more expensive driver solution than the 87130A. If your choice of switch matrix platform is VXI, VXI I/O cards are also available.

3. Routing internal switch indicator circuits to a rear panel connector provides TTL high and low states to be read by an external device. This external device can be an Agilent 3488A with I/O card or a customized solution.

Readback may be combined with front panel LEDs, which indicate switch and attenuator positions, and these can be combined with a silk-screened front panel signal flow schematic. This feature is an excellent software and hardware troubleshooting tool, since the operator can tell at a glance which path is activated. Although it is a useful feature, a front panel schematic can be expensive. Also, the LEDs require extra engineering and assembly time for the DC wiring and circuitry required to drive them.

Manual switches

Matrices can also be controlled manually using front and back panel manual switches. This feature is attractive for applications in which the ATE system must be troubleshot in a remote area. If you have the manual control option, you don’t need to be in the computer room to change a path, since all paths may be selected from the matrix front panel.

Since additional mechanical and electrical design time is needed, as well as about 30 percent more assembly time, this feature adds cost to your matrix.

Ordering Process

Agilent accepts orders for custom switch matrices in two ways: build-to-print and build-to-spec.

Build-to-print means you provide the RF design and Agilent builds the matrix. However, there is usually some additional engineering required to create DC schematics, a mechanical layout, assembly and test procedures, and the cable design for the automatic bending process. Also, in some cases, Agilent designers may suggest some modifications to the original design to reduce cost and/or add capabilities.

In the case of build-to-print, we need a detailed RF schematic of the matrix and the bill of materials. We guarantee that we will build the unit exactly as designed. The specifications are therefore governed by your design.

When you contact your Agilent sales representative about a build-to-print order, he/she will ask you for the diagram and bill of materials. The representative will then work with Agilent designers to provide you with a formal proposal. In this proposal, we define the deliverables, price and delivery of the units. Agilent requests that a copy of the proposal signed by you accompany the order to ensure agreement on the deliverables.

In the case of build-to-spec, you provide the specifications and Agilent designs, assembles, and delivers a complete solution. The Agilent representative will provide you a switch matrix specification form to fill out. (Appendix A contains the switch matrix specification form.) The answers to the questions on this form give the engineers all the information needed to design the optimized switch matrix and provide you a quote for price and delivery. If you have a written specification, please include a copy along with the Agilent specification form. Agilent will then provide a proposal based on this information. The proposal will include a block diagram of the design, the guaranteed specifications and, if applicable, exceptions to some parameters. In many cases, there will be a direct interaction between you and Agilent designers to make sure we are designing exactly what you need. We may also make suggestions for price reductions or design improvements. As in the build-to-print case, Agilent requires a signed copy of the proposal with the order.

Upon receiving the order, Agilent designs the matrix based on the agreed specifications. When the design phase is complete, you get one more opportunity to review the design and give your final approval before the fabrication phase begins.

Deliverables

Your custom switch matrix is delivered to you with a complete service manual. The manual includes RF schematics; DC wiring diagrams; a complete parts list; front, rear, and internal mechanical layouts; and all the information you need to service the unit. The matrix is normally backed with a one-year warranty.

Conclusion

Agilent will design and manufacture a custom switch matrix for your ATE system using the detailed information you provide on the switch matrix specification form. Our expert sales and engineering team works with you during the design phase to ensure that your matrix is optimized for your application, with the features and functions that you require.

Appendix A

Switch matrix specification form

Date: _____ Customer Name: _____

Project#: _____ (Agilent internal)

Standalone Matrix Part of: _____ Quantity: _____

Block diagram/Schematic provided: Yes No

Full Access Common Highway

Blocking (each input to one output at a time)

Non-blocking (each input to any/all outputs)

of inputs _____ # of outputs _____

Note: Ask your Agilent representative for information regarding the above matrix design choices.

Physical/mechanical specs

Mechanical:

What platform is requested? _____ (i.e., VXI, MMS, System II, custom, or don't care)

Size/Space/Weight constraints? _____

Connectors requested:

RF: _____ Other: _____

Connector type, locations and layout constraints (i.e., front or rear):

Input: _____ Output: _____

Auxiliary components required? _____

Need rack slides? Yes No

Flanges: Yes No with handles without handles

Environmental testing required? Yes No If yes specify: _____

Environmental specs required? Yes No

If yes specify: _____

User Interface: _____

Mode of control: GPIB Manual Both Other

Type of switch driver: _____

*Indicators required? Yes No LED's Readback

*Front panel schematics required? _____

*Special layout/mechanical/electrical requirements: _____

*Requires extra design and assembly effort. May increase the price of your matrix significantly.

Power supply:

Voltage _____ Current _____

Customer-specified parts list (i.e., attenuators, amplifiers, filters, etc.):

_____ } Need specs, mechanical
_____ } drawings, etc.

Customer furnished equipment: { } Yes { } No

Functional/electrical specs

Frequency range: _____

Insertion loss/gain:

Frequency Max Min Max. input power Rqd. output power

If specs are different for each matrix path, please fill out Table 1 (below). If available, please provide us a block diagram.

VSWR: _____ Are unused I/O's terminated? _____

Isolation: _____

Equal paths/phase matching: { } Yes { } No

If yes: What is the tolerance and over what frequency? _____

Which path(s) does this apply to? _____

Other/active component spec (e.g., noise figure, conversion loss, distortion, or spurious):

Please fill out this form as completely as possible. A blank represents NO SPECIFICATION to our engineering team. Agilent uses best design practice to give you the best possible solution for your requirements.

Table 1. Insertion Loss/Gain Specifications

Path	Max	Min	Max input power	Rqd. output power	VSWR	Isolation	Unused I/O's terminated
1							
2							
3							
4							
5							
6							
7							
8							
9							
10							

Appendix B

Popular Agilent coaxial switches

Agilent Model	Frequency Range	Features	Product Category																		
			SPDT Configurable Connectors	SPDT High Performance	SPDT High Reliability	Transfer High Performance		Multiport Low-profile				Multiport High Performance									
						4-port	5-port	SP3T	SP4T	SP5T	SP6T	SP4T	SP6T								
8761A	dc to 18 GHz	• 1 million cycles • Selectable connector configuration	X																		
8761B	dc to 18 GHz		X																		
8762A	dc to 4 GHz	• 1 million cycles																			
8762B	dc to 18 GHz	• High repeatability		X																	
8762C	dc to 26.5 GHz	• All-ports terminated		X																	
8762F (75 Ω)	dc to 4 GHz	• Current interrupts and position indication capability • TTL/5V CMOS option		X																	
8763A	dc to 4 GHz	• 1 million cycles					X														
8763B	dc to 18 GHz	• High repeatability					X														
8763C	dc to 26.5 GHz	• 1-port terminated • Current interrupts and position indication capability • TTL/5V CMOS option					X														
8764A	dc to 4 GHz	• 1 million cycles						X													
8764B	dc to 18 GHz	• High repeatability						X													
8764C	dc to 26.5 GHz	• Underterminated • Current interrupts and position indication capability • TTL/5V CMOS option						X													
8765A	dc to 4 GHz	• Highest frequency range			X																
8765B	dc to 20 GHz	• 5 million cycle			X																
8765C	dc to 26.5 GHz	• High repeatability			X																
8765D	dc to 40 GHz	• Underterminated			X																
8765F (75 Ω)	dc to 4 GHz				X																
8766K	dc to 26.5 GHz	• 5 million cycles							X												
8767K	dc to 26.5 GHz	• High repeatability								X											
8768K	dc to 26.5 GHz	• Underterminated									X										
8769K	dc to 26.5 GHz	• Current interrupts and position indication capability										X									
87104A	dc to 4 GHz	• 5 million cycles															X				
87104B	dc to 20 GHz	• High repeatability											X								
87104C	dc to 26.5 GHz	• All-ports terminated															X				
87106A	dc to 4 GHz	• Optoelectronic interrupts and position indicators • TTL/5V CMOS option																	X		
87106B	dc to 20 GHz																			X	
87106C	dc to 26.5 GHz																				X
87204A	dc to 4 GHz	• 5 million cycles											X								
87204B	dc to 20 GHz	• High repeatability																X			
87204C	dc to 26.5 GHz	• All-ports terminated																X			
87206A	dc to 4 GHz	• Optoelectronic interrupts and position indication																		X	
87206B	dc to 20 GHz																			X	
87206C	dc to 26.5 GHz																				X

Specifications				
Agilent Model	8766K	8767K	8768K	8769K
Configuration	SP3T	SP4T	SP5T	SP6T
Features	Unterminated Break-before-make Current interrupts Position indication capability ¹			
Impedance	50 Ω			
Frequency range	dc to 26.5 GHz			
Insertion loss (dB)	Signal path Common to port 1: 0.2 dB + 0.05 dB x f (GHz) Common to port 2: 0.2 dB + 0.06 dB x f (GHz) Common to port 3: 0.2 dB + 0.08 dB x f (GHz) Common to port 4: 0.25 dB + 0.095 dB x f (GHz) Common to port 5: 0.25 dB + 0.108 dB x f (GHz) Common to port 6: 0.25 dB + 0.12 dB x f (GHz)			
SWR (through line)	<1.3 to 8 GHz <1.5 to 12.4 GHz <1.6 to 18 GHz <1.8 to 26.5 GHz		<1.3 to 8 GHz <1.55 to 12.4 GHz <1.8 to 18 GHz <2.05 to 26.5 GHz	
Isolation (dB)	See chart on page 102			
Input power	1 W			
Average Peak²	100 W (10 μs max)			
Switching time (max)	30 ms			
Repeatability (max)³	0.01 dB to 18 GHz 0.05 dB to 26.5 GHz			
Life (min)	5,000,000 cycles			
RF connectors	3.5 mm (f)			
DC connectors	Viking cable connector			
Options				
Supply voltage, Current, and impedance	Std.	Opt. 011	Opt. 015	
Supply voltage range	20 to 30 Vdc	4.5 to 7 Vdc	13 to 22 Vdc	
Supply voltage (nom)	24 Vdc	5 Vdc	15 Vdc	
Current (nom)	130 mA	332 mA	187 mA	
Impedance (nom)	185 Ω, 65 mH	17 Ω, 5.5 mH	80 Ω, 30 mH	
RF connectors	Opt. 002: SMA (f) ⁴			
DC connectors	Opt. 008: 8-inch ribbon cable			
	Opt. 016: 16-inch ribbon cable			
Calibration documentation	See ordering information			

1. Provides position sensing when used with Agilent 87130A/70611A switch driver or customer supplied external circuitry.
2. Not to exceed 1 W average (non-switching).
3. Measured at 25° C.
4. Use to 18 GHz only.

Specifications

Agilent Model	87104A 87104B 87104C	87106A 87106B 87106C	87204A 87204B 87204C	87206A 87206B 87206C
Configuration	SP4T	SP6T	SP4T	SP6T
Features	Terminated Break-before-make or make-before-break Optoelectronic current interrupts Optoelectronic position indicator ¹ Internal control logic		Terminated Break-before-make or make-before-break Optoelectronic current interrupts Optoelectronic position indication capability ² Direct path control	
Impedance	← 50 Ω →			
Frequency range	← A: dc to 4 GHz B: dc to 20 GHz C: dc to 26.5 GHz →			
Insertion Loss (dB)	← 0.3 + 0.015 x freq (GHz) →			
SWR	← <1.2: dc to 4 GHz <1.35: 4 to 12.4 GHz <1.45: 12.4 to 18 GHz <1.7: 18 to 26.5 GHz →			
Isolation (dB)	← >100 dB: dc to 4 GHz >80 dB: 12 to 15 GHz >70 dB: 15 to 20 GHz >65 dB: 20 to 26.5 GHz →			
Input Power	← 1 W →			
Average	← 50 W (10 μs max) →			
Peak³	← 50 W (10 μs max) →			
Switching Time (ms)	← <15 →			
Repeatability (max)⁴	← 0.03 dB →			
Life (min)	← 5,000,000 cycles →			
Supply Voltage and Current	← 20 to 32 Vdc →			
Supply Voltage Range	← 20 to 32 Vdc →			
Supply Voltage (nom)	← 24 Vdc →			
Current (nom)⁵	← 200 mA →			
RF Connectors	← SMA (f) →			
DC Connectors	← Ribbon cable receptacle →			

Options

	87104A,B,C	87106A,B,C	87204A,B,C	87206A,B,C
Control logic	Opt. T24: TTL/5V CMOS compatible logic with 24 Vdc supply		← N/A →	
DC connectors	←	Opt. 100: Solder terminals		→
Calibration Documentation	←	See ordering information		→

1. Position sensing when used with customer supplied external circuitry only.
2. Position sensing when used with Agilent 87130A/70611A switch driver or customer supplied external circuitry.
3. Not to exceed average power (non-switching).
4. Measured at 25° C.
5. Closing one RF path requires 200 mA. Add 200 mA for each additional RF path closed or opened.

Appendix C

Agilent switch drivers and interface modules

Agilent 11713A attenuator/switch driver

The 11713A attenuator/switch driver provides simple GPIB control of up to ten 24 Vdc solenoid-activated switches or attenuator sections. The 11713A supplies 24 Vdc common and ten pairs of current sinking contacts to control up to 10 relays. The internal 24 Vdc power supply of the 11713A can deliver control signals totaling 0.625 amps continuously or 1.25 amps for one second. Each 11713A comes equipped with two plug-in drive cables for driving attenuators. Other cables are also available. The convenient front panel controls allow manual control of individual attenuator sections and/or switches.

Agilent 70611A attenuator/switch driver for MMS

The 70611A is a 1/8 MMS module capable of driving up to 248 electromechanical switches or attenuator switch sections. The 70611A is MSIB, SCPI, and GPIB compatible. In addition to being programmable, the 70611A features an extremely user-friendly manual interface via any MMS display unit. The highlight of the manual interface is the operator's ability to customize groups of switch control lines and their settings, then identify these switch settings with user-defined alphanumeric labels. In this manner, end users of the 70611A can define custom menus with their own identification labels for simplified manual control.

The 70611A can store up to 256 user-defined, labeled paths. Path definitions can be stored in non-volatile EPROM. Groups of paths can be stored in "directories" for easier access to similar path commands. The 70611A controls switches or attenuator sections in banks of 31 (eight banks total) through individual Agilent 84940A I/O driver cards, which are in turn directly wired to the switches and/or attenuators.

Agilent 70612/613 series MMS interface modules

In addition to custom interface modules, Agilent offers off-the-shelf interface solutions in MMS. The 70612 (1 x 6 switch tree) series and 70613 (2 x 5 switch tree) series are microwave matrixes

available in 2/8 MMS modules with integrated controllers. They are equipped with front panel indicators to facilitate manual use, and the integrated controller has all the capabilities of the 70611A attenuator/switch driver. A variety of options are available for the 70612/13 series, including performance to 26.5 GHz, terminated or unterminated switches, integrated attenuators and a choice of port locations. For a more detailed description of these products, refer to publication number 5091-4897E, *Modular Measurement System Data Sheet*.

Agilent 87130A attenuator/switch driver

The 87130A is a 3.5-inch high (2 rack units), full rack width attenuator/switch driver capable of driving up to 248 electromechanical switches or attenuator sections. The 87130A is controlled over GPIB via standard commands for programmable instruments (SCPI). The 87130A has been designed for use in both ATE switching systems and computer controlled bench-top applications. Control and programming are accomplished via application programs in IBASIC, RMB, C, or Pascal. An ITG driver is also available for use separately or in conjunction with Agilent's Visual Engineering Environment (VEE).

The 87130A is electronically identical to the 70611A and shares its performance characteristics with the exception of the method of manual control. The 87130A has no front panel controls. Manual control of the 87130A is realized through its ITG driver and a computer controller. The 87130A can drive 31 switches or attenuator sections directly and up to an additional 217 switches via seven additional Agilent 84940A driver cards. A distribution board, 84941A (see opposite), is available to facilitate the interconnection of the 87130A to switches or attenuators.

Agilent E1368A, E1369A, and E1370A VXI attenuator and switch drivers

Agilent's VXI family of instrumentation includes modules for microwave switching and attenuation control up to 18.0 GHz. The E1368A contains three

factory-installed SPDT switches such as the Agilent 8762B which feature all-port termination, dc to 18.0 GHz. The E1369A is identical to the E1368A except that the switches are not included. This allows user-substitution of Agilent 8763/64 series transfer switches. The E1370A allows the user to customize the internal configuration for Agilent 8766 series multiport switches or 8494/95/96/97 series step attenuators.

For more information, request a copy of the Agilent VXI catalog, publication number 5964-3970E (5964-6898E in CD format).

Agilent 84940A switch driver and Agilent 84941A distribution card

The 84940A is an expansion driver card for the 70611/12/13 family of MMS attenuator/switch drivers and the 87130A attenuator/switch driver. The 84940A has been designed for incorporation into large interfaces located remotely from their controller. A single 84940A can control up to 31 switches and can be located up to 150 feet (45 m) from an Agilent 70611/12/13 or Agilent 87130A. The physical interconnection to the switches or attenuators is realized via 31 four-pin output connectors which permit quick connection and disconnection of the switches or attenuators. The 84941A is a signal distribution card designed to simplify the interconnection of the drive cable from 87130A to the 31 components directly driven by these controllers. The 84941A also provides 31 four-pin connectors for convenient interconnection to switches or attenuators. Included with the Agilent 84941A is a pack of 31 cables, to connect as many as 31 switches or attenuator sections to the 84941A.

Agilent Technologies' Test and Measurement Support, Services, and Assistance

Agilent Technologies aims to maximize the value you receive, while minimizing your risk and problems. We strive to ensure that you get the test and measurement capabilities you paid for and obtain the support you need. Our extensive support resources and services can help you choose the right Agilent products for your applications and apply them successfully. Every instrument and system we sell has a global warranty. Support is available for at least five years beyond the production life of the product. Two concepts underlie Agilent's overall support policy: "Our Promise" and "Your Advantage."

Our Promise

"Our Promise" means your Agilent test and measurement equipment will meet its advertised performance and functionality. When you are choosing new equipment, we will help you with product information, including realistic performance specifications and practical recommendations from experienced test engineers. When you use Agilent equipment, we can verify that it works properly, help with product operation, and provide basic measurement assistance for the use of specified capabilities, at no extra cost upon request. Many self-help tools are available.

Your Advantage

"Your Advantage" means that Agilent offers a wide range of additional expert test and measurement services, which you can purchase according to your unique technical and business needs. Solve problems efficiently and gain a competitive edge by contracting with us for calibration, extra-cost upgrades, out-of-warranty repairs, and on-site education and training, as well as design, system integration, project management, and other professional services. Experienced Agilent engineers and technicians worldwide can help you maximize your productivity, optimize the return on investment of your Agilent instruments and systems, and obtain dependable measurement accuracy for the life of those products.

Get assistance with all your test and measurement needs at:
www.agilent.com/find/assist

Product specifications and descriptions in this document subject to change without notice.

Copyright © 1998, 2000 Agilent Technologies
Printed in U.S.A. January 17, 2001
5966-2916E



Agilent Technologies

Innovating the HP Way